

Eclipse 5.5 Gold Water Jet 66" x 42" x 23"

SKU: ECLIPSE-55-GWJ



GOLD WATER JET

TECHNICAL SPECIFICATIONS	
Drain	End drain
Pump Configuration: Select 1	Std. = Standard / Alt LF/RF Optional
Bath Weight (empty)	145 lbs
Gallons to Operate	50-65
ELECTRICAL SPECIFICATIONS	
Motor/Pump	(1) 115v 20AMP GFCI Circuits
Inline Stainless Steel Heater	(1) 115v 20AMP GFCI Circuit

BATHERS: 1	
INSTALLATION	
•	DECK (D)
	UNDER MOUNT (U)
	ALCOVE (A)
	FREESTANDING (F)
	CLAWFOOT (L)
	PEDESTAL (P)

Jet & Control placement may vary



STANDARD FEATURES & ACCESSORIES for GOLD WATER JET

JETS

12 Water Massage Jets
 Back Massage System(s) (6 Jets)
 Accumassage Back and Neck Jets ⊕
 6 Ultra Flow Jets ⊕

PUMPS

3.25 Hydropower 3-speed Pump
 Quiet Pad Anti-Vibration Mounted Pump

HEATERS

Stainless Steel Electric Heater

CONTROLS

Air Switch On/Off Control(s) For Hydro Pump & Mood Light
 3 Speed Massage: High, Medium or Low

PURITY

HydroClean Water Purity System
 HydroCleanse

STANDARD ACCESSORIES

Mood Light
 Lift & Turn Drain - White, Biscuit, Bone, Brushed Nickel,
 Oil Rubbed Bronze, Polished Chrome
 Deluxe Cushion Pillow
 EZ Level Adjustable Legs
 FDA Recipe Non-Toxic Food & Beverage Grade Plumbing (primarily)
 30 Point Quality Assurance Factory Test

REQUIREMENTS

Pump Locations: Select 1
 Electrical: two 115v 20AMP GFCI Circuits
 Drain: Select Color / Finish

Tub should not be supported by the lip in any way.

Level tub & screw or glue adjustable legs to sub floor.

CUT OUT DIMENSIONS:

OVALS: A template will be provided

RECTANGLES: Subtract 1" to 1.5" from length & width for hole cut out size

EZ CLEAN CAST ACRYLIC LIMITED LIFETIME WARRANTY

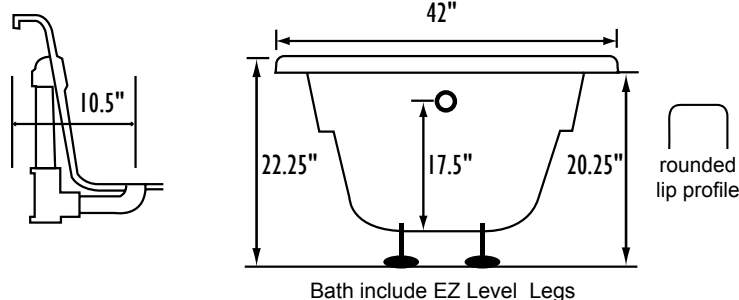

INSTALLATION WILL NOT REQUIRE MORTAR BEDDING

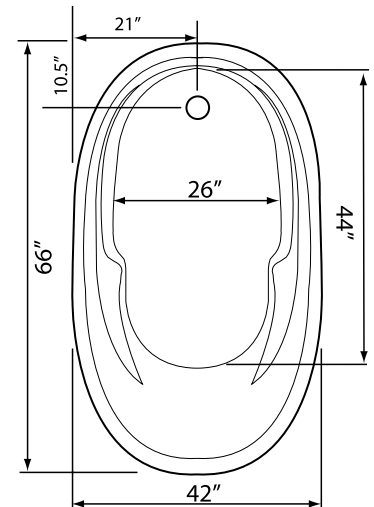
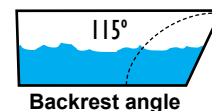
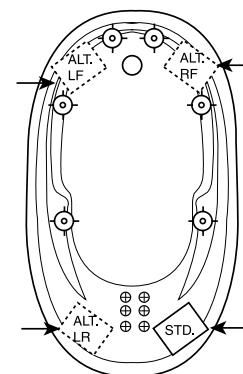

Some standard & most alternate pump locations may stickout past perimeter of the bath 1"-3". NOTE: Graphics may not be to scale. Specifications and features are subject to change without notice and are ± .25". All final measurements should be taken from tub on site. Access 18"x 18" or larger is required for each pump. Consult your contractor for installation requirements.