

Rosabella Gold Air 72" x 42" x 27.5"

PRODUCT NUMBER: ROSABELLA-GAIR-K



GOLD AIR

TECHNICAL SPECIFICATIONS	
Drain	Side drain - Required - specify finish
Pump Location(s): Select 1	Remote blower or access panel Model A
Bath Weight (empty)	225 lbs
Gallons to Operate	77-112
ELECTRICAL SPECIFICATIONS	
Motor/Pump	(1) 115v 20AMP GFCI Circuits

BATHERS: 2	
INSTALLATION	
	DECK (D)
	UNDER MOUNT (U)
	ALCOVE (A)
•	FREESTANDING (F)
	CLAWFOOT (L)
	PEDESTAL (P)

Jet & Control placement may vary

Space available for deck mounted or floor mounted faucet



JETS

18 EZ Clean™ Air Jets on Sidewall **X**

PUMPS

1.25 Air Power Variable Speed, Pulse & Wave heated Air Pump
Quiet Pad Anti-Vibration Mounted Pump

HEATERS

Warm Back Rest Tubing Zone

CONTROLS

Air Switch On/Off Control(s) for Mood Lighting
Variable Speed Air Massage Control
Automatic Purge & Dry Cycle Control

PURITY

HydroCleanse

STANDARD ACCESSORIES

Mood Light
Deluxe Cushion Pillow
FDA Recipe Non-Toxic Food & Beverage Grade
Plumbing (primarily)
30 Point Quality Assurance Factory Test

REQUIREMENTS

Pump Locations: **Select access panel model (A) for blower access through the tub surround.**

Or select remote air pump model where air pipe will run under the floor to the desired blower location up to 15' away from the bath.

Electrical: one 115v 20AMP GFCI Circuits

EZ CLEAN CAST ACRYLIC

LIMITED LIFETIME WARRANTY 

DRAIN REQUIRED

with integral overflow and Flush Press -
Select finish: Brushed Nickel, Oil Rubbed Bronze, Polished Chrome (not included)

FAUCET

Either Deck Mount or Floor Mount (not included)



- A** **X** HTT® Leg Therapy Air Massage System includes 10 Air Jets on the floor. Optional on Combo Plat and Combo Gold Series
- B** **X** 6 Jet HTT® Back Massage System: N/A on Combo Series-Standard on Plat series
- C**  Warm Back Tubing Zone

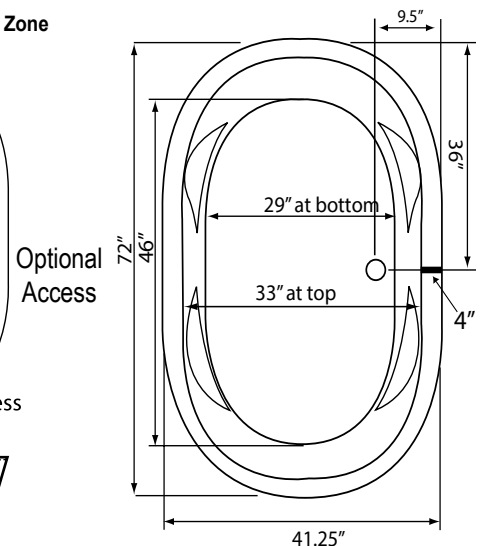
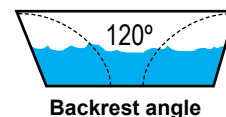
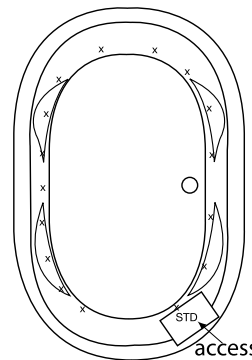
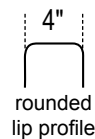
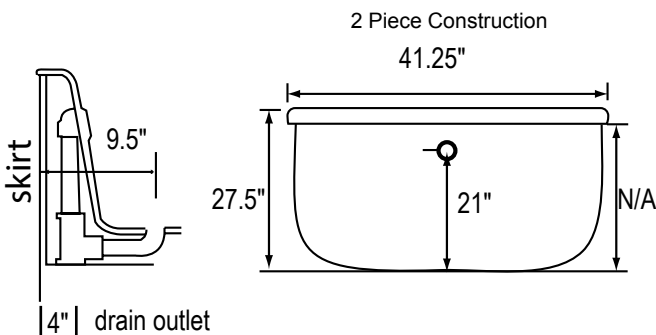

Some standard & most alternate pump locations may stickout past perimeter of the bath 1"-3". NOTE: Graphics may not be to scale. Specifications and features are subject to change without notice and are ±.25". All final measurements should be taken from tub on site. Access 18"x 18" or larger is required for each pump. Consult your contractor for installation requirements.